

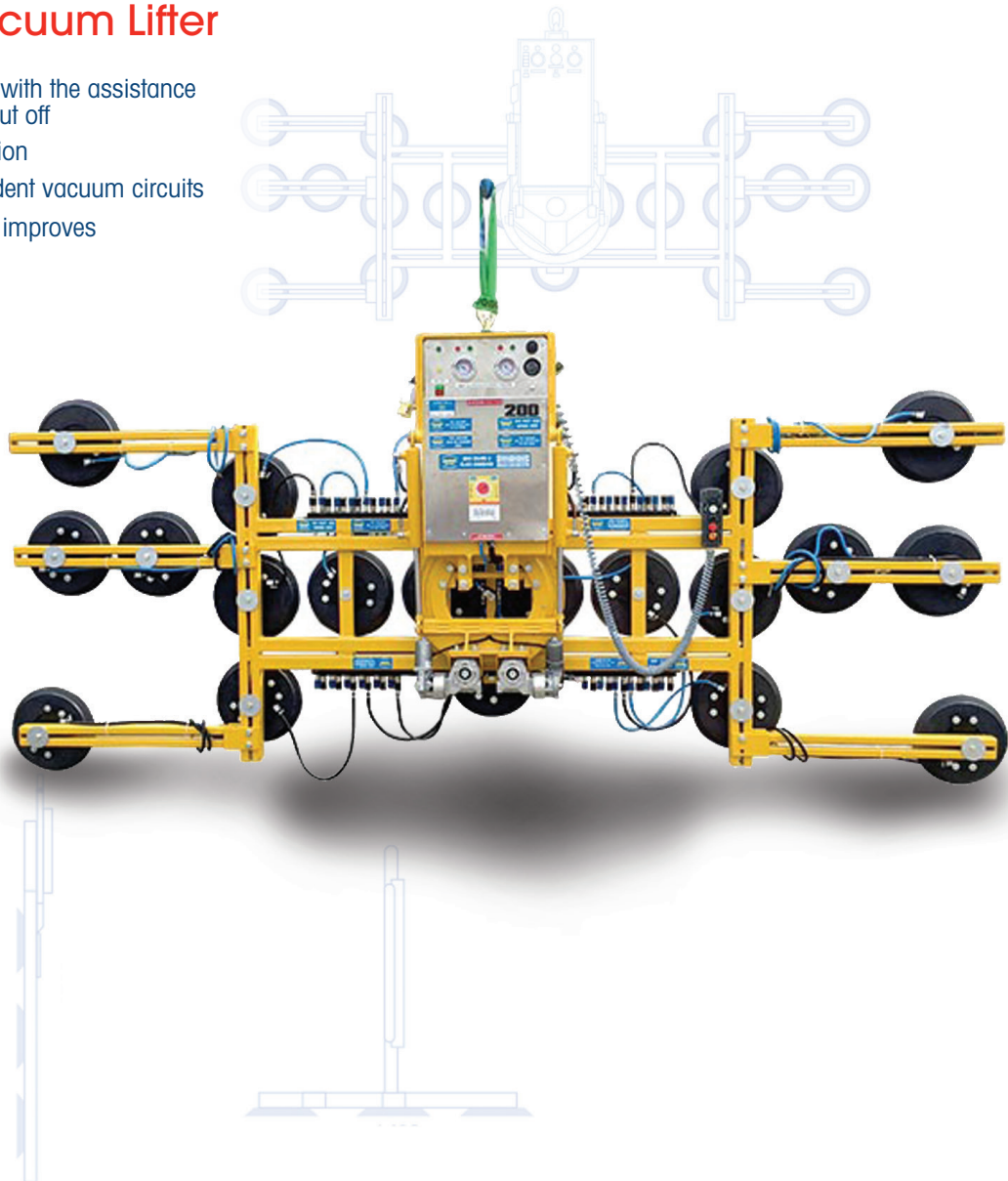

1500KG

Dual Circuit - Vacuum Lifter

- Irregular loads can be lifted with the assistance of individual suction pad shut off
- Remote control tilt and rotation
- Very powerful dual independent vacuum circuits
- Powered tilting and rotation improves material handling
- Wheeled stand
- Low vacuum alert



UP & DOWN LIFTING SOLUTIONS • 335 Waydom Drive, Ayr Ontario, N0B1E0

Email: rentals@upanddown.ca • Tel: 519-588-5438 or 519-575-5438 or 1-844-401-9723

www.upanddown.ca

1500KG Dual Circuit - Vacuum Lifter

 270° Rotation

 90° Tilt

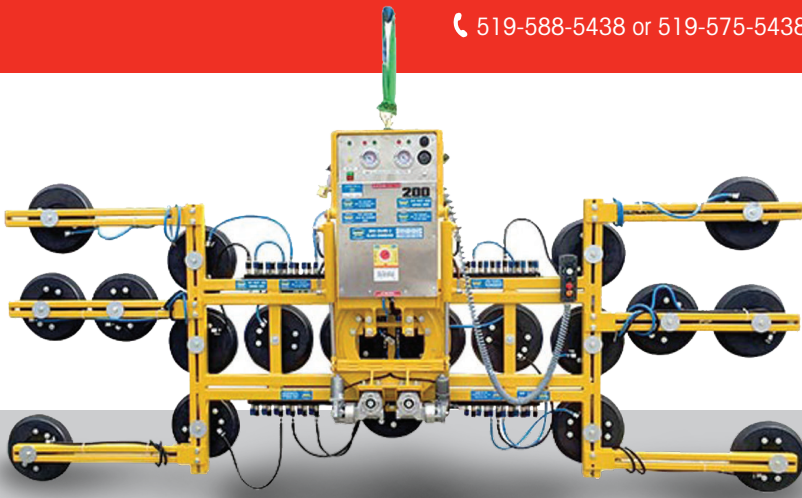

TECHNICAL DATA

Description	Value			
Dimensions:	HxWxD mm 875mm (1480 max) x 3600mm x 300mm			
Vacuum system:	Dual Circuit 2 or 4 Pumps, 2 Vacuum Tanks			
Suction cup quality:	Black Rubber, Not Abrasion Resistant, Heat Resistant Up to 100°C			
Suction cup dimension:	3300mm			
Number of suction cups:	20	16	12	8
Loading capacity of frame: (on smooth and clean surface at 60% vacuum)	1500kg	1200kg	900kg	600kg
Weight of lifter:	250kg	220kg	156kg	148kg
Structural depth:	300mm			
Output:	1.5m ³ /h			
Voltage: pump:	12v DC from 2 Rechargeable Batteries			
battery charger:	110v/240v 50/60Hz Single Phase Factory Selectable			
Accessories:	Radio Remote Control, Wheeled Trolley			

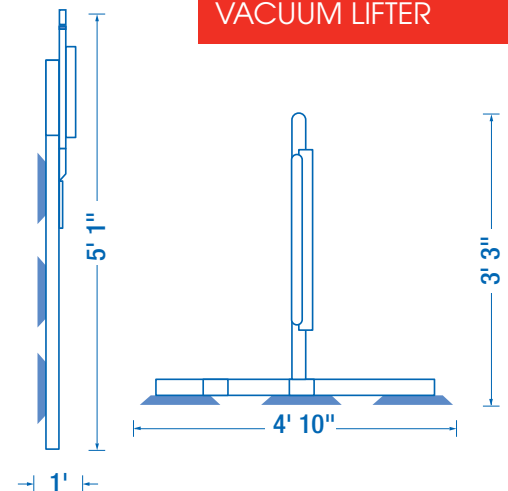
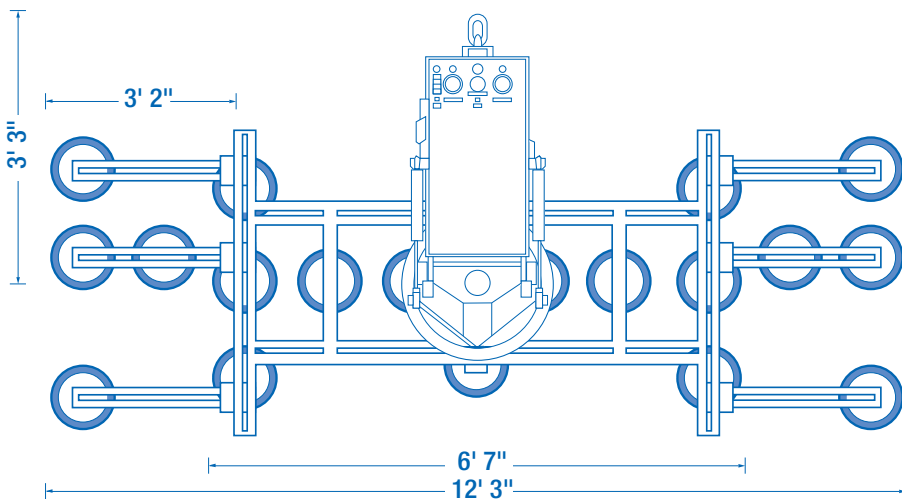

1500KG DUAL CIRCUIT / VACUUM LIFTER